

FALCON 500 SERIES



FALCON 500 series
Standard frame, motorized CNC X-Y stage



FALCON 500 series

Micro/Macro Vickers & low force Brinell hardness tester

The FALCON 500 series, Micro Vickers, Vickers and Micro Brinell hardness testing machines are a new generation of instruments, improving conventional hardness testing methods and focused on eliminating user influence on the test results.

The unique force actuator system utilizes an electronically controlled closed loop system and advanced force sensor technology, to achieve absolute accuracy, reliability and repeatability, on each of the forces used for a test.

Besides this advanced electromechanical force application system, the FALCON offers superior quality mechanical and optical components, used to complete the instrument.

The innovative software functions of IMPRESSIONS™ workflow control allow file storing, test program setting and storing, image zoom, auto focus, limit settings, conversions to other hardness scales, system setup and (remote) control, pattern testing (CHD/Nht/Rht) and widely contributes to the high reproducibility of test results.

Fully automatic image evaluation combined with intuitive operator software avoid operator influence on the test results.

A rock solid frame structure, that can withstand the harshest environment, is covered by shock and damage proof ABS covers. The covers avoid damage to the machines high tech interior and stay in a good condition over the years to come. No dents or paint damage from fallen work pieces. Replacement of the covers, if required as all, is easy and economic.

The FALCON series beating heart is a powerful embedded micro system controller with no moving or running parts and entirely packed in a chip and dust proof enclosure. The system is easy to service and can be exchanged in just minutes if ever required.

Stunning force range

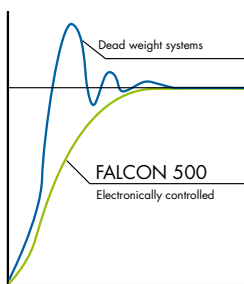

Stunning force range:
0.001Kgf up to 62.5Kgf over load cell, closed loop system.

Electronically controlled loads secure a quick and precise load application as well as a quick method change. A touch on the screen makes the correct setting and expedites automatic Z-axis positioning to the focus level, for any of the objectives or indentors chosen.

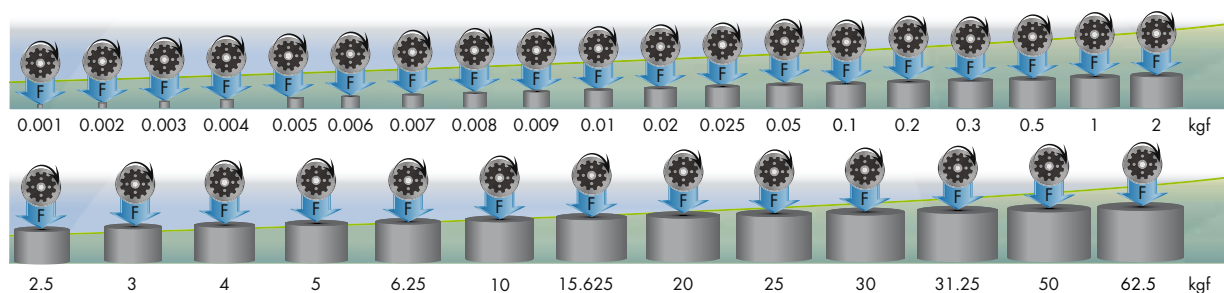

FALCON 500

Extended frame, motorized CNC X-Y stage



Overview of test force configurations

Test force versus model number

3g	501	2kg	62.5kg
1g	10g	503	10kg
1g	200g	505	31.25kg
1g	10g	507	31.25kg
1g	508	31.25kg	62.5kg
1g	200g	509	62.5kg
1g	10g	510	62.5kg
1g	511		62.5kg

Note: See page 13 for order details

Scales and testing methods, depending on force configuration

Vickers - DIN EN ISO 6507, ASTM E-384

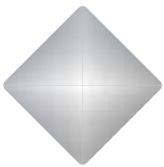

HV0.001	HV0.002	HV0.003	HV0.004	HV0.005	HV0.006
HV0.007	HV0.008	HV0.009	HV0.010	HV0.015	HV0.020
HV0.025	HV0.050	HV0.1	HV0.2	HV0.3	HV0.5
HV1	HV2	HV2.5	HV3	HV4	HV5
HV10	HV20	HV25	HV30	HV40	HV50

Knoop - DIN EN ISO 4545, ASTM E-384



HK0.01	HK0.02	HK0.025	HK0.05	HK0.1	HK0.2
HK0.3	HK0.5	HK1	HK2	HK5	

Brinell - DIN EN ISO 6506, ASTM E-10

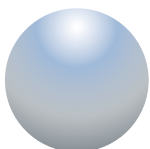

HB1/1kgf, HB1/2.5kgf, HB1/5kgf, HB1/10kgf, HB1/30kgf;
 HB2.5/6.25kgf, HB2.5/15.625kgf, HB2.5/31.25kgf, HB2.5/62.5kgf
 HB5/25kgf, HB5/62.5kgf

IMPRESSIONS™

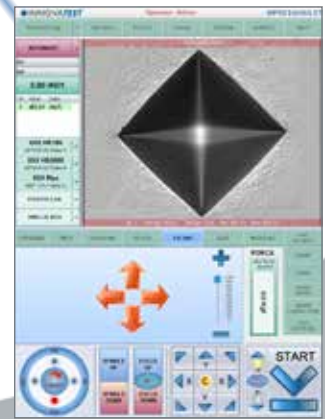
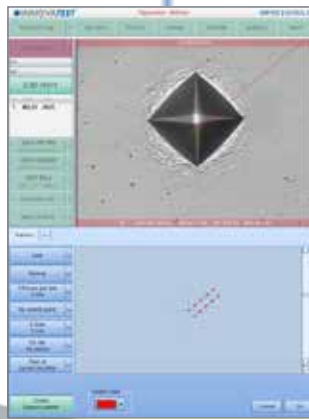
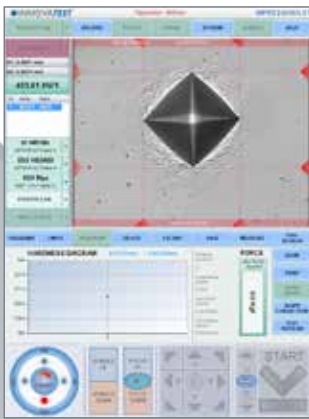
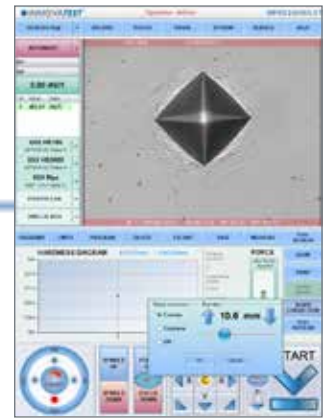
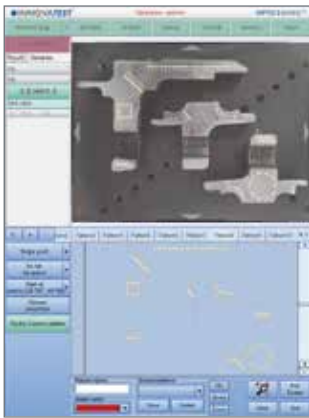
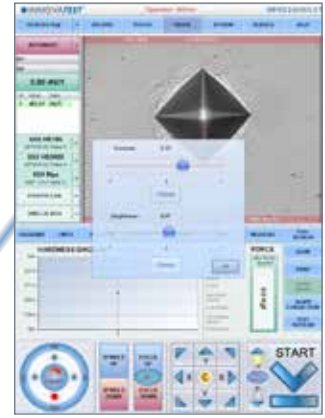
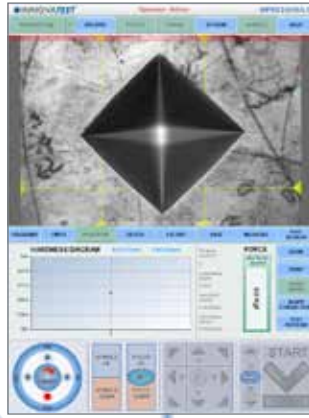

Standard functionality

Intuitive operator interface IMPRESSIONS™

IMPRESSIONS™ is the ultra-modern user interface of all Innovatest hardness testing machines. IMPRESSIONS™ offers unparalleled simplicity in operation but yet, includes the most advanced functions found in hardness testing. With only a minimum of operator skills required, IMPRESSIONS™ leads you through the set up process, in just seconds, not even minutes. Standard features, complex tasks and advanced work flow at your fingertips.

Typical examples are:

Scale setting, Test methods setting, Limits, Conversion to other hardness scales, Graphics, File saving, Test program saving, Zoom function, Full screen, Test pattern, CNC stage control, Focus control, Z-Axis control.

All standardized hardness testing methods have been programmed in the software and can be selected at any time.

Fully automatic image evaluation

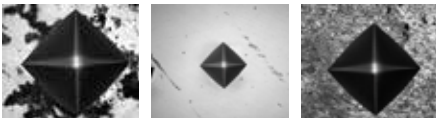

IMPRESSIONS™ tester control evaluates sharpness and brightness of all camera images and measures the indentation independent of the operator.

The automatic adjustment of the picture parameters ensures reproducible test results, even for different materials and difficult, scratched or damaged test surfaces.

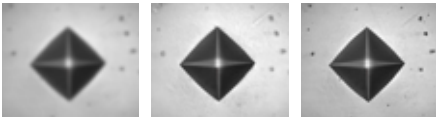

The standard fast auto-focus technology guarantees a sharp image of the indentation, in just a few seconds.

Indent zoom magnification

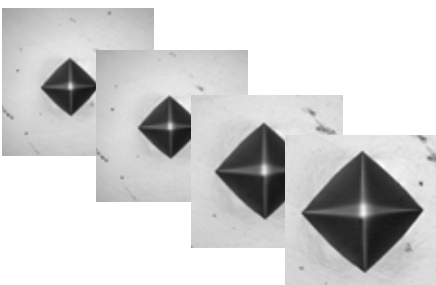

Calibrated stepless zoom of the indent image provided by the objective, while maintaining the same high standard of image quality.

This unique zoom system is a standard feature on the entire FALCON series.

Combined with the 4 objectives installed on the 6 position turret, the zoom system allows a further magnification of the indentation, even up to 2500X.

Safety first/collision detection system

In order to ensure maximum safety for the user, but also to protect the tester against user errors, all FALCON models have an advanced collision detection, warning & Z-axis retraction system.

This system is triggered by any uncommon force on the turret and will stop & retract the Z-axis in milliseconds. Fingers, hands and work pieces are safe, but also damage to indenters and objectives belong to the past.

More standard functionality...

Dynamic Z-Axis height adjustment



Intelligent Precision positioning of the work piece is a standard feature on the FALCON series.

The 2 button control system allows ultra-fast pre-positioning, while the scroll wheel provides a pulse by pulse control on the actual fine adjustment of the focus position.

A dynamic system, as the speed depends on the selected magnification of the vertical microscope and camera system.

Speed varies further by the velocity of the scroll wheel and is therefore in perfect harmony with the displacement feeling feedback to the operator.

* All FALCON 500 models have a standard auto-focus system!

User defined programs



Save/load/delete work piece tester settings.

Set up your tester as required for your work piece, save the settings with a specific name or number. This function reduces the tester setup efforts for the operator and significantly increases safety and efficiency.

All user-specific settings for the particular work piece such as; test method, objective, pattern settings etc., are stored on the testers dual SSD drives, RAID system.

Report generator



The IMPRESSIONS™ system incorporates a very advanced report generator.

The report generator allows you to publish all testing results and graphics, including pictures of the indentations in an easy to edit and easy to customize file size. You can add your company details and change the reporting lay-out to your requirements.

All reports can be printed on a connected (optional) standard printer without the need of a personal computer or any interface.

Reports can be exported to excel or word or simply stored as PDF on the systems hard disks.

Variable configurations...

Advanced measuring methodes



Single measurement

This function allows you to set individual test points wherever you like.

The test measurement can be started using the surface view or the overview.



Serial measurement

One or more test rows with positioning coordinates can be recorded.

The measuring process can be started in the surface view or the overview.



CHD/Nht/Rht measurement

For the performance of test series for CHD/Nht/Rht data of specimen according to standard. The test can be started directly from the surface view or from the overview.

Additional core points of hardness can be defined separately for Nht measurements.

Sample testing can be defined graphically to scale.

Quick and precise positioning by one mouse click, offers rapid pattern testing set up.

Perfect overview thanks to live vision technology.

Make any fixed pattern or design custom patterns. Multi pattern testing on multi samples based on live overview and macro viewing technology. Copy test patterns, modify or "drag & drop" patterns from one test sample to the other test sample. Live vision technique over zoom and macro camera's, no image stitching required.

Edge recognition (Optional) allows to make a test pattern following the test sample surface line.

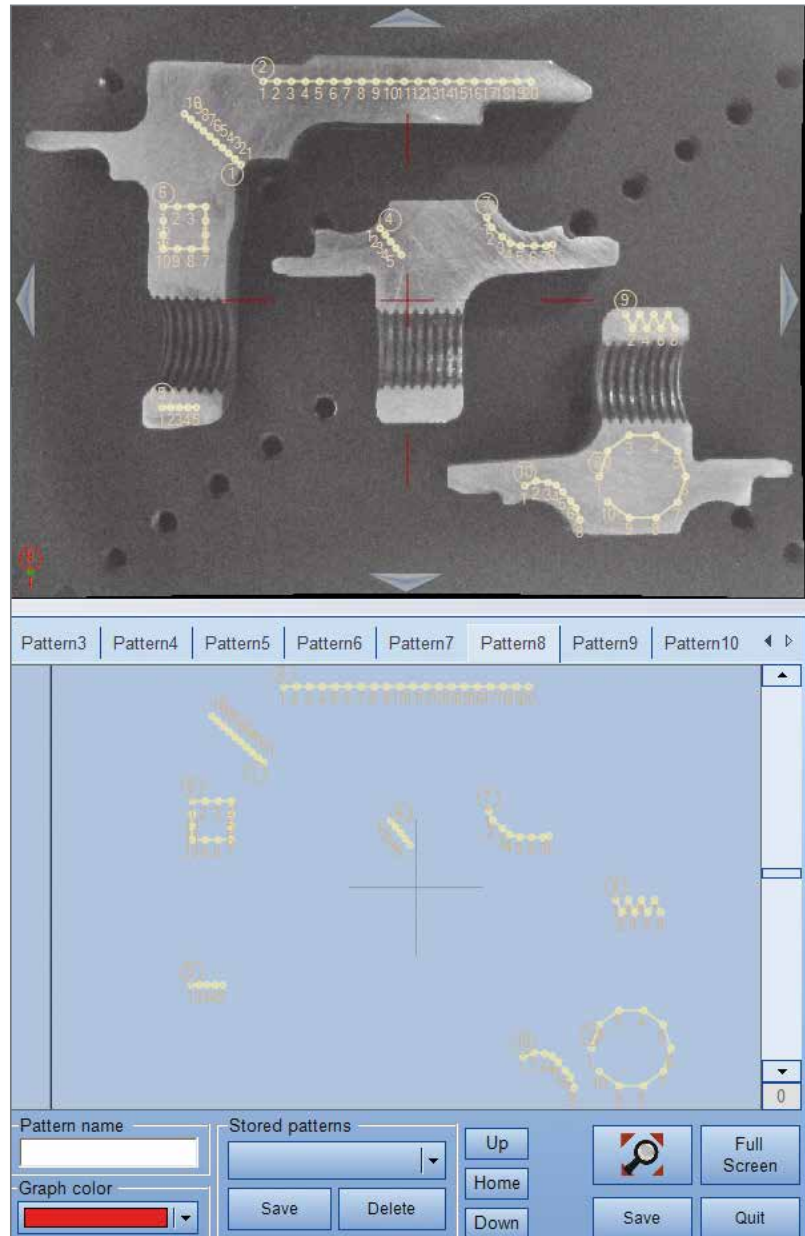

What FALCON 500 offers more...

Overview & full view zoom cameras

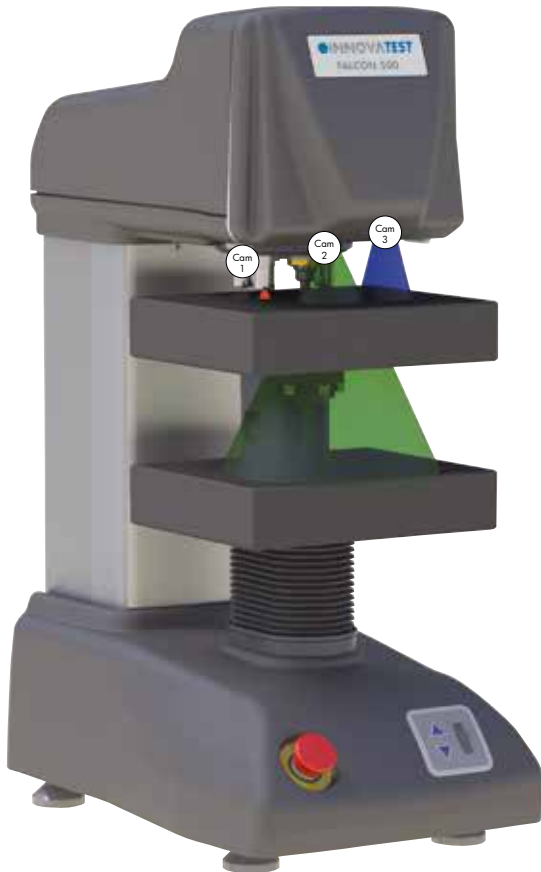

Unique TRIPLE camera system

Falcon has the option to install 2 additional camera's for maximum operator comfort.

Unique in the world of Vickers and Micro Vickers measurement, the triple camera system provides not only automatic measurement and an indent zoom system, but also full working area overview (zoom optics) and macro work piece overview for accurate positioning or test area recognition with a crisp image quality.

CAM1 (Measurement, autofocus)

The standard HD auto focus camera handles indent view at a top quality level (red beam)

Field of view depends on final objective, plus 2x digital magnification, up to 2500x.

CAM 2 (Zoom Overview, auto focus)

The second HD camera (green beam) provides nearly full stage view while remaining sharpness and focus regardless of the stage height position. Ideal for testing multiple objects of the same or different dimensions by just clicking on the required test positions.

Field of view 50mm x 37mm to 200mm x 160mm

CAM 3 (Macro, auto focus)

The third macro camera has a field of view up to 50mm x 37mm, on work piece surface level, ideal for high quality surface viewing of the heat affected zone of welding samples. Field of view 25mm x 18.5mm to 50mm x 37mm (Zoom 1:2). This unique, for the hardness testing field, camera system allows users the largest possible flexibility, without the need of time consuming "image stitching / scanning".

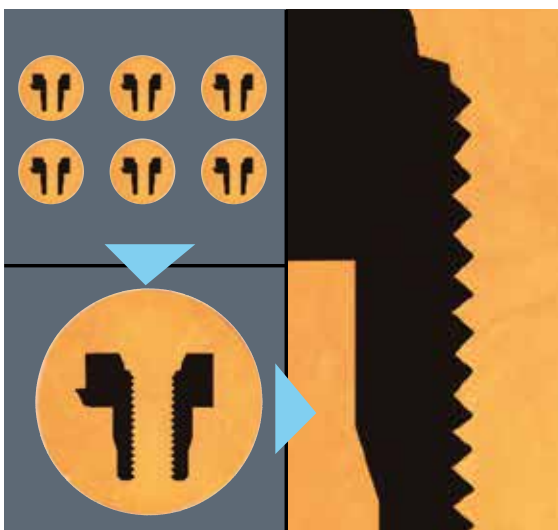

The optional overview & full view autofocus zoom cameras with additional surface illumination, ensures a perfect overview or full view on your sample or samples.

IMPRESSIONS™ "click and go" functionality allows random test point selection on the screen, while the high speed motorized X-Y stage perfectly positions the selected test point under the indenter and measuring objective.

*Picture: Embedded sample(s),
Top left multi sample overview by zoom overview camera,
Down left zoom on one sample,
Right zoom on segment of one sample.*

Variable configurations...

Advanced turret / precision Z-axis

Hi Tech "collision protected" turret & load application system

Multi load cell technology with the highest possible force repeatability, high speed digital electronic circuits and advanced, complex algorithms provide an ultra-fast positioning turret, free to configure as per your requirements.

Protected against damage due to collision with a work piece or stage. The anti-collision system protects not only the tester and the work piece but also indenters and objectives against operator failure under all circumstances.



High speed 6 positions precision turret.

The standard high speed modular 6 positions turret swivels motorized into the correct required position. The positions are automatically selected while the system checks which indenter and objective are most suitable for the selected test, to be performed.

The turret can be configured to request, with either 1 indenter actuator or 2 indenter actuators combined with maximum 4 objectives at choice.

The second indenter position can also be retrofitted at any moment after installation.

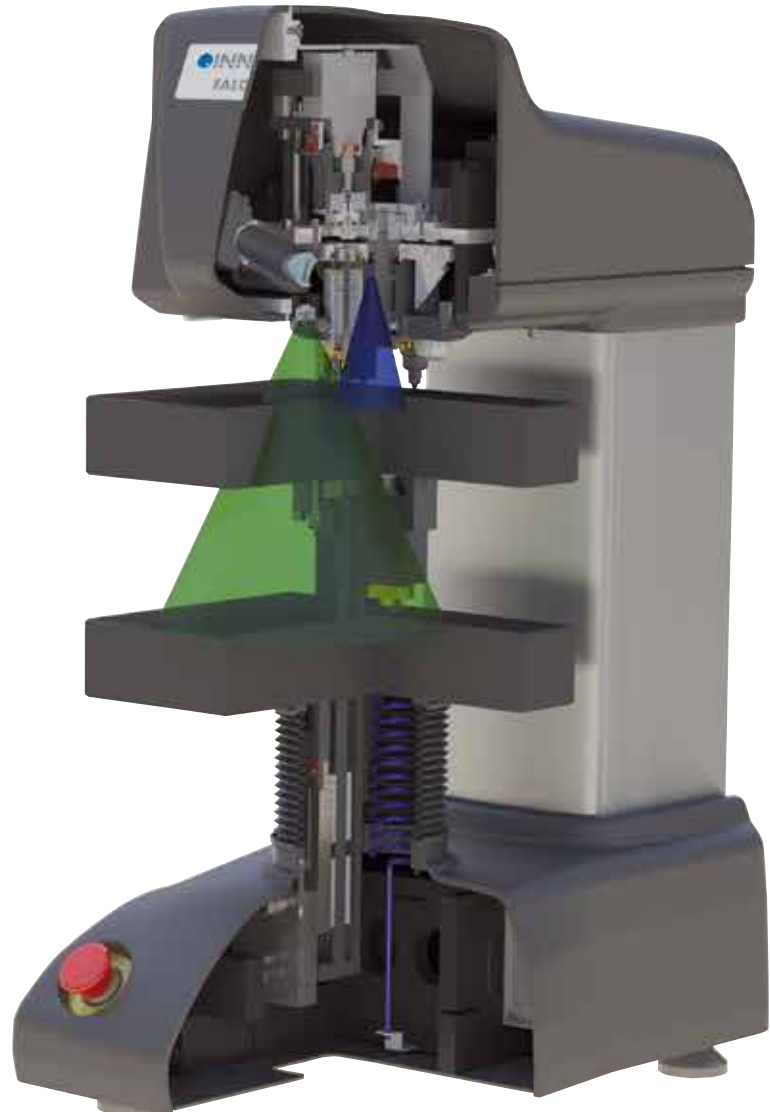

Ultra precise Z-axis movement

The Z-axis height adjustment of the motorized or manual work table is provided by a high precision linear slide. In combination with a ball bearing spindle, this high quality ultra-precise system allows superfast focusing and guarantees unparalleled accuracy in work piece positioning. All advantages of a moving test head and fixed surface testing height in one advanced solution.

FALCON 501

Standard frame, manual X-Y stage



Technical specifications

FALCON 500

Hardness scale	(Micro-) Vickers, Knoop & Brinell
Load application	Load cell, force feedback, closed loop system
Load range	1gf up to 62.5Kgf
Motorized turret	6 positions; 2 indenter positions, 4 objectives positions
Optical system	High definition, 5Mpx machine Vision system
Objectives	2.5x, 5x, 10x, 20x, 40x, 60x, 100x
Overview camera Cam 2	5Mpx optical ZOOM camera, field of view 50 x 37mm / 200 x 160mm
Macro camera Cam 3	5Mpx auto focus camera, field of view 25 x 18.5mm / 50 x 37mm
Electronic system	High performance embedded micro system controller, MS Windows® , 15" full color industrial touch screen, automatic and manual measurement
Test loads (depending model)	1gf, 2gf, 3gf, 4gf, 5gf, 6gf, 7gf, 8gf, 9gf, 10gf, 20gf, 25gf, 50gf, 100gf, 200gf, 300gf, 500gf, 1kgf, 2kgf, 2.5kgf, 3kgf, 4kgf, 5kgf, 6.25kgf, 10kgf, 15.625kgf, 20kgf, 25kgf, 30kgf, 31.25kgf, 50kgf, 62.5kgf
Vickers test range	HV0.001, HV0.002, HV0.003, HV0.004, HV0.005, HV0.006, HV0.007, HV0.008, HV0.009, HV0.010, HV0.015, HV0.020, HV0.025, HV0.050, HV0.1, HV0.2, HV0.3, HV0.5, HV1, HV2, HV2.5, HV3, HV4, HV5, HV10, HV20, HV25, HV30, HV40, HV50
Brinell test range	HB1/1kgf, HB1/2.5kgf, HB1/5kgf, HB1/10kgf, HB1/30kgf; HB2.5/6.25kgf, HB2.5/15.625kgf, HB2.5/31.25kgf, HB2.5/62.5kgf HB5/25kgf, HB5/62.5kgf
Knoop	HK0.01, HK0.02, HK0.025, HK0.05, HK0.1, HK0.2, HK0.3, HK0.5, HK1, HK2, HK5
Indentors	Factory indentors or certified indentors (ISO / ASTM) (optional)
Test cycles	Fully automatic, automatic and manual
Standards	Complies to or exceeds, ISO, ASTM, JIS (Nadcap) standards
Test force tolerance	<0.5% for test force 100gr to 62.5kg, <1% for test force below 100gr
Display resolution	0.1 HV, HK, 0.5 HB
Hardness conversion	Rockwell, Rockwell Superficial, Brinell, Leeb & Tensile
Statistics	Total test, max, min, average, range, standard deviation, all in real time after each test
Data storage capacity	Dual SSD 80Gb, RAID system
Connectivity	2 USB ports, RJ45 Ethernet LAN, W-LAN, RS-232, Blue Tooth, 5 Axis CNC & motorized X-Y stage connector
Dwell time setting	Default 10 seconds, user defined 1 to 99 seconds (1 sec increments)
Printer	A4, A3 full colour laser printer (optional)
Manual stage dimensions	Stage 100mm x 100mm, Travel 25mm x 25mm, Reading 0.01mm
Motorized stage dimensions	See pag. 14
Operating temperature	10°C to 35°C, non-condensing
Humidity	10% to 90% non-condensing
Machine dimensions	525mm x 323mm x 773mm
Machine weight	75kg
Power consumption	100W
Power supply	100VAC to 240VAC, 50/60Hz, single phase

CNC stages, connectivity & order details

Anvils, X-Y stage or CNC motorized X-Y stage



The basic version provides a manual X-Y stage and a plane anvil with all the requirements for quick and easy single tests.

The FALCON allows to expanded to a wide choice of motorized X-Y stages while the IMPRESSIONS™ tester control and workflow software has many advanced positioning functions, from single indent to advanced pattern testing. The onboard controller allows up to 5 axis CNC work piece positioning.



Super fast, high accurate motorized CNC X-Y stages:

Article code	Surface	Travels	Models
UN-XY571210	250 x 205mm	120 x 100mm	500 (most common)
UN-XY571712	300 x 225mm	170 x 120mm	500
UN-XY572212	350 x 225mm	220 x 120mm	500
UN-XY572216	350 x 265mm	220 x 160mm	500

Advanced connectivity



RJ45
Ethernet



RS 232



The powerful embedded micro controller running MS Windows® provides an almost unlimited connectivity to the outside world, wired, or not. Multiple USB ports, RJ45 LAN, W-LAN, BlueTooth, RS-232, HDMI & VGA are available on all FALCON models.

Order details

Falcon 500 series

FALCON 501	3g – 2kgf,	Vickers & Knoop, large frame	2kgf
FALCON 503	10g – 10kgf,	Vickers, Knoop & Brinell, large frame	10kgf
FALCON 505	200g – 31.25kgf,	Vickers, Knoop & Brinell, large frame	31.25kgf
FALCON 507	10g – 31.25kgf,	Vickers, Knoop & Brinell, large frame	
FALCON 508	1g – 31.25kgf,	Vickers, Knoop & Brinell, large frame	
FALCON 509	200g – 62.5kgf,	Vickers, Knoop & Brinell, large frame	62.5kgf
FALCON 510	10g – 62.5kgf,	Vickers, Knoop & Brinell, large frame	
FALCON 511	1g – 62.5kgf,	Vickers, Knoop & Brinell, large frame	

Note: The large frame models have extended vertical & extended horizontal work space.

STANDARD configurations, features & accessories

Standard features on all models

- Load cell, closed loop force control
- IMPRESSIONS™ operator control
- Auto Brightness
- Auto Contrast
- Auto Sharpness
- Auto Focus
- Automatic indent measurement
- Anti-collision system for objectives and indenters
- Calibrated step less Indent ZOOM system
- Auto save, program setup, data storage,
- Motorized Z-axis
- Z-axis intelli control
- 2 indenter positions, 4 objective positions
- Quality optical system
- 5mp HD camera
- High power LED vertical illuminator with filter position
- Powerfull Embedded Micro Controller; MS Windows™, 80gb dual SSD data storage keyboard & mouse
- 15" portrait mode, HD industrial touch screen on adjustable table stand
- Connectivity; 4 USB ports, RJ45 Ethernet LAN, W-LAN, RS-232, Blue Tooth, motorized X-Y stage controller



Standard configuration & accessories

- 1 Indenter position/actuator installed
- 1 INNOVATEST Vickers Indenter
- 1 INNOVATEST reference hardness block
- 1 Objective 10X
- 1 Objective 40X (20X low force (200g) models)
- Manual X-Y stage 100mm x 100mm, travel 25mm x 25mm
- Wireless mouse and keyboard
- Vice for small work pieces
- Clamp for thin work pieces
- Chuck for round work pieces
- 4 Vibration dampers
- Installation & Operator manual
- Power cable
- Spare fuse
- Certificate of calibration



OPTIONAL configurations, features & accessories

Optional features (software)

- CAM 2 (Zoom Overview, auto focus), Full stage view camera, ideal for testing multiple objects of the same or different dimensions by just clicking on the required test positions. Field of view 50mm x 37mm to 200mm x 160mm
- CAM 3 (Macro, auto focus), Macro camera, field of view up 25mm x 18.5mm to 50mm x 37mm (Zoom 1:2), on work piece surface level, ideal for high quality surface viewing.
- Click & Go software for random point testing (requires motorized X-Y stage & Overview camera)
- Pattern testing (requires motorized X-Y stage)
- CHD, Nht, Rht (requires Pattern testing and motorized X-Y stage)

Optional configuration & accessories

- Certified indentors (ASTM, DIN, ISO)
- Certified reference hardness blocks (ASTM, DIN, ISO)
- Motorized CNC precision, ultra-fast positioning X-Y stage (select model for required travel distances)
- Motorized CNC rotary table
- Motorized CNC dividing head
- CAM 2 (Zoom Overview, auto focus), Full stage view camera, ideal for testing multiple objects of the same or different dimensions by just clicking on the required test positions. Field of view 50mm x 37mm to 200 x 160mm
- CAM 3 (Macro, auto focus), Macro camera, field of view up 25mm x 18.5mm to 50mm x 37mm (Zoom 1:2), on work piece surface level, ideal for high quality surface viewing.
- 2th indenter position/actuator factory installed
- Large round measuring table 150mm
- Objective 2,5X
- Objective 5X
- Objective 10X
- Objective 20X
- Objective 40X
- Objective 60X
- Objective 100X
- V-anvil for 1-6mm
- V-anvil for 4-20mm
- Precision vice 50mm
- Precision vice 75mm
- Precision vice 100mm
- 1 Sample holder 30mm
- 1 Sample holder 40mm
- 1 Sample holder 50mm
- 6 Sample holder 30mm
- 6 Sample holder 40mm
- 6 Sample holder 50mm
- Round 3-jaw chuck 80mm
- Vibration free table for low force testing
- Vibration free table top, for low force testing
- 15" Industrial LCD touch screen
- Full colour laser printer (A4, A3)

Manual stage options

- Digital stage micrometer, for standard manual stage, travels 25mm

Motorized CNC X-Y stages

Article code	Surface	Travels	Models
• UN-XY571210	250 x 205mm	120 x 100mm	500
• UN-XY571712	300 x 225mm	170 x 120mm	500
• UN-XY572212	350 x 225mm	220 x 120mm	500
• UN-XY572216	350 x 265mm	220 x 160mm	500



Technical Drawing FALCON 500

All dimensions are in mm

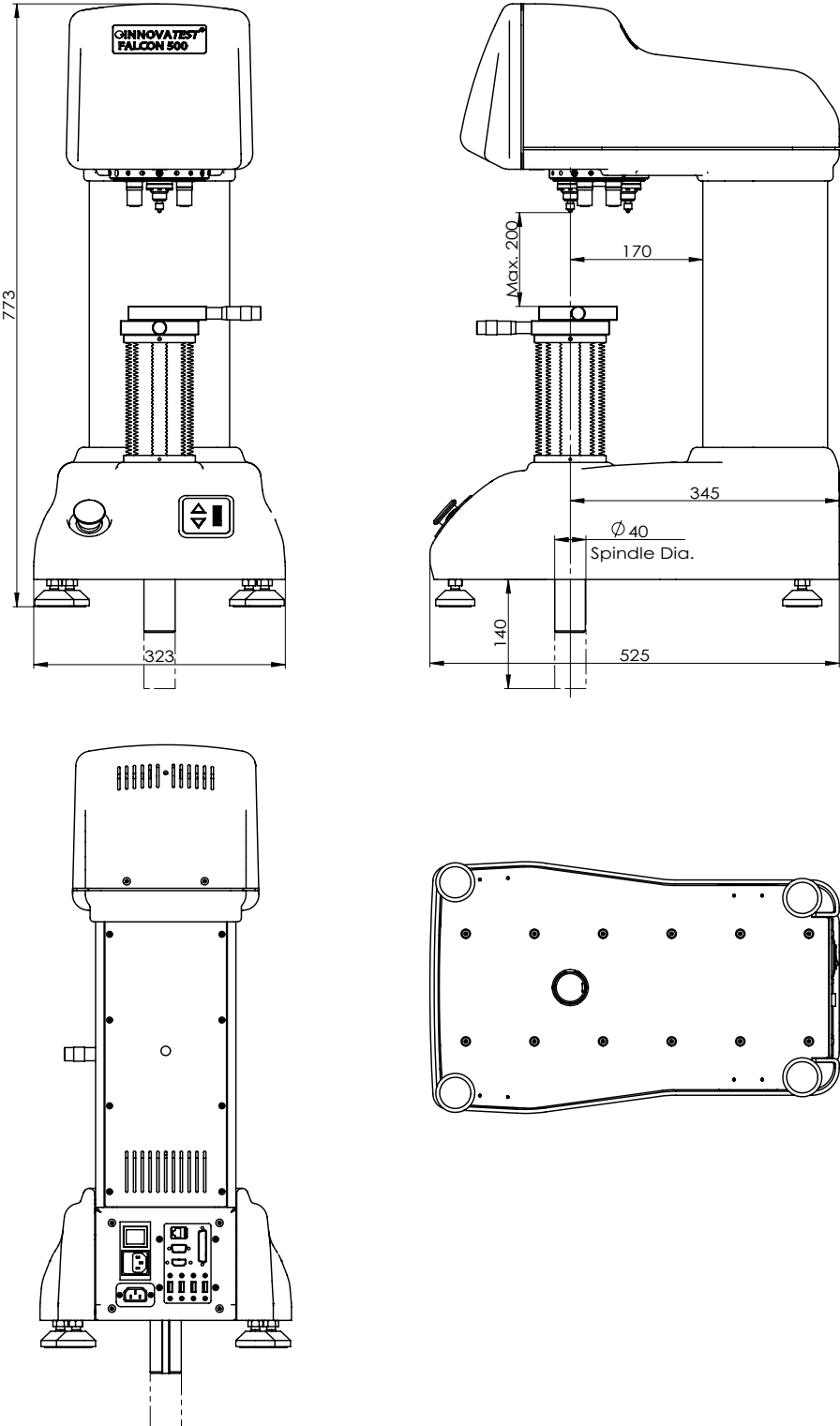



FALCON 500 working table

Features

- Large stand: 1500mm x 750mm x 825mm (UN-STAND/965), suitable for Vickers, Micro-Vickers and automated systems (PC and video systems)
- 100% retractable drawer, bearing guidance, max 100kg load. Rubber anti slip bottom
- Lockable cabinet, 300mm high
- Adjustable feet, (+/- 50mm height adjustable to reach ergonomic working position)
- Made of corrosion resistant zinc plated steel with RAL powder coating
- Carrying capacity of 400kg
- Top surface made of 50mm Plywood with 1.5mm chemical resistant plastic plating, edges made of shock resistant 3mm ABS side liner
- Industrial quality, for workshop or laboratory
- Designed for hardness testing instruments, painted in INNOVATEST® RAL colors that match with the testers.

Technical Specifications

Dimensions	1500mm x 750mm x 825mm, large high bench tester stand (UN-STAND/965)
Drawer	150mm
Cabinet	300mm high (lockable)

Standard Delivery

- Steel frame with table top
- 100% retractable drawer with anti-slip
- Lockable cabinet
- Adjustable feet



All dimensions are in mm

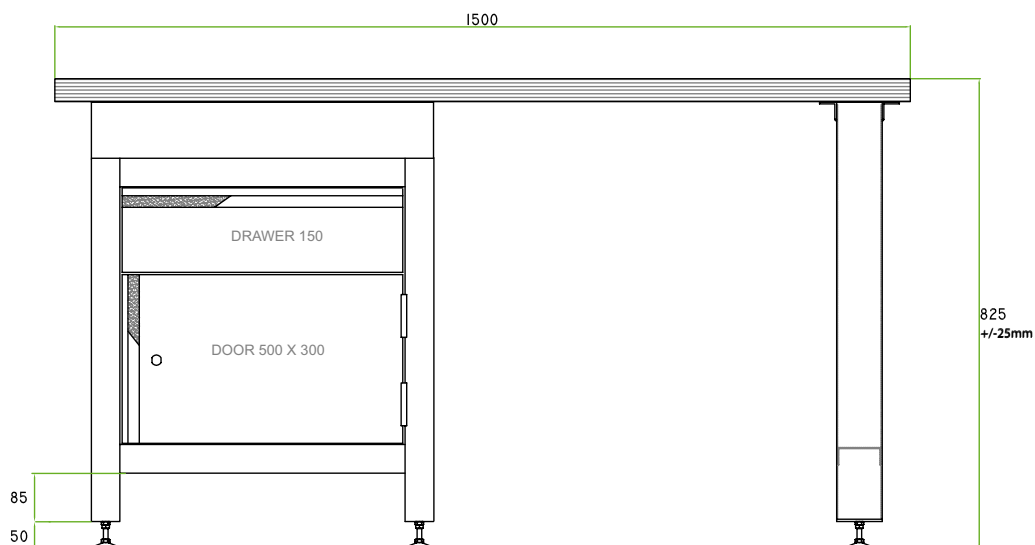

Represented by :



Gnehm Härteprüfer AG
Bönirainstrasse 13, 880 Thalwil
Tel. +41 (0) 44 725 43 42 Fax +41 (0) 44 725 96 05
vertrieb@gnehm-haertepreuefer.ch
www.gnehm-haertepreuefer.ch



CORPORATE HEAD OFFICE

INNOVATEST Europe BV MANUFACTURING, DISTRIBUTION & SERVICE

Borgharenweg 140
6222 AA Maastricht (The Netherlands)
Phone: +31 43 3520060
Fax: +31 43 3631168
E-mail: info@innovatest-europe.com
Website: www.innovatest-europe.com

INNOVATEST has a global presence for sales and service. Please contact our head office for contact details on the nearest branch office or distributor.

INNOVATEST Shanghai Co., Ltd. DISTRIBUTION, SALES & SERVICE

Building 2, No.123, 1165 Nong Jindu Road,
South Metropolis Industrial Park
Minhang District, Shanghai, P.R. China
Zip code: 201108
Phone: +86 21 60906200
Fax: +86 21 60912595
E-mail: info@innovatest-shanghai.com
Website: www.innovatest-shanghai.com

INNOVATEST Polska Sp. z o.o. SALES & SERVICE

ul. Komornicka 127
62-051 Wiry, Polska
Phone : +48 697 099 826
E-mail info@innovatest-polska.pl
Website: www.innovatest-polska.pl

INNOVATEST Japan Co., Ltd. SALES & SERVICE

3-36-13, Horinouchi, Suginami-ku,
Tokyo, Japan 166-0013
Phone: +81 4 2937 7540
Fax: +81 4 2937 7542
E-mail: info@innovatest-japan.com
Website: www.innovatest-japan.com

INNOVATEST South East Asia CUSTOMER SUPPORT CENTER

20 Sin Ming Lane #05-58 Midview City
Singapore 573 968
Phone: +65 6451 1123
Fax: +65 6452 1011
E-mail: info@innovatest-singapore.com

Changes in products and/or product specifications can emerge due to new technologies and continuous development. We reserve the right to change or modify specifications of the products without prior notice. We recommend you to contact our sales office for up-to-date information. © All rights reserved